

PLAN VIEW

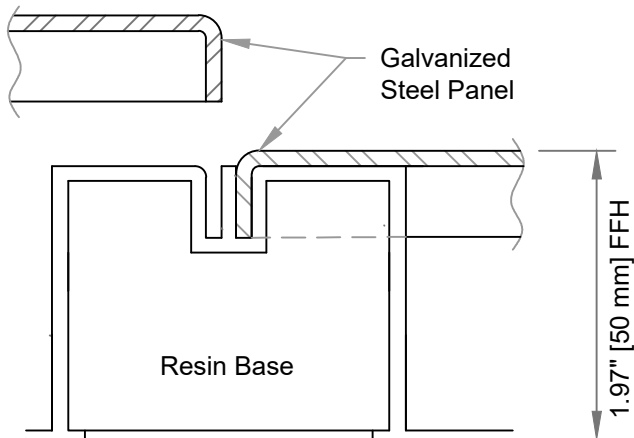

SIDE VIEW

PHYSICAL DATA

- Weight of System - 3.8 psf (18.6 kg/m²)
- Height of System - 1.97" (50 mm)
- Fire Rating of Bare Panel:
Class A Flame Spread
Non-Combustible Materials
- Fire Rating of Resin Understructure:
 - Designed for use in Type I (fire-resistive) and Type II (non-combustible) classified buildings per IBC Section 603.1:
 - Combustibility Class CC1 in accordance with ASTM D635
 - Self-Ignition Temperature greater than 650°F (343°C) in accordance with ASTM D1929
 - Maximum Average Smoke Density rating less than 75 in accordance with ASTM D2843
- NFPA 253 Class I Floor Finish in accordance with ASTM E648

PERFORMANCE DATA

- Concentrated Live Load - 2,000 lbf (8.90 kN)
Per IBC Table 1607.1
- Concentrated Point Load - 500 lbf (2.22 kN)
Per CISCA Test Procedures, Section 1
- Uniform Live Load - 2,000 lbf (8.90 kN)
Per IBC Table 1607.1
- Ultimate Load Safety Factor - 2-to-1 Min.
Per CISCA Test Procedures, Section 2
- Rolling Loads - 10 Pass
 - CISCA Wheel A (3" Dia.) - 460 lb.
 - 8" Dia. x 2" Semi-Pneumatic - 500 lb.

FINISH OPTIONS

- Bare surface galvanized steel

FEATURES

- Available at 1.97" (50 mm) FFH
- Prefabricated before shipment
- Easy to install
- Heavy-Duty quick-connect steel plates
- Easy to change layout and cable wiring
- No adhesive required
- No underlayment required
- No fasteners required